

# Atmosphere Pro 2.5"

## Invisible Trim Housing



### SPECIFICATIONS

**Input:** Universal 120 - 277V AC 50/60 Hz

**Standards:** ETL & cETL, IC-rated, Airtight (see below for list)

**Dimming:** 2 Channel 0-10V: 100-0.1%;  
2 Channel DMX 512 RDM: 100-0.1%  
Linear dimming, 1st input channel intensity changing, 2nd input channel is CCT changing.

**Mounting:** New construction housings included with universal mounting brackets and hanger bars  
Ceiling cut out (Round): Ø 4 ¼"  
Ceiling cut out (Square): 4 ¼" x 4 ¼"  
See next page for ceiling thickness information

**Fixture Type:**

**Catalog Number:**

**Project:**

**Location:**

**Construction:** 20 Gauge cold rolled steel  
Diecast spackle flange included

**Warranty:** 8 year product warranty

### HOUSINGS

	Model		Power	Rating	Driver
New Construction	<b>A1RA-247</b>	Round	<b>1</b> 15W <b>2</b> 22W	IC rated, Airtight Non-IC, Airtight	<b>CT-X</b> DMX <b>CT-Z</b> 0-10V
New Construction	<b>A1RA-257</b>	Square	<b>1</b> 15W <b>2</b> 22W	IC rated, Airtight Non-IC, Airtight	<b>CT-X</b> DMX <b>CT-Z</b> 0-10V

Example: **A1RA-2472-CT-Z**

Round New Construction

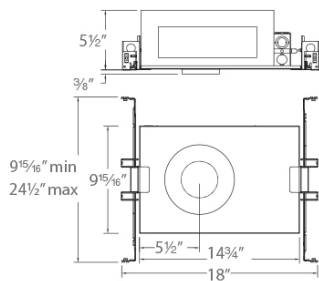

Square New Construction

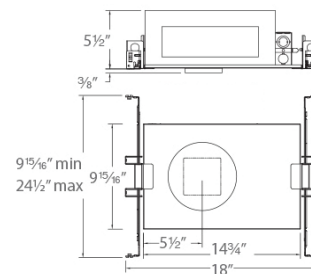
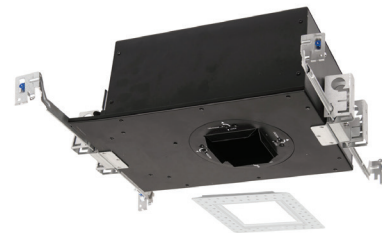

aispire.com  
Phone (800) 526.2588  
Fax (800) 526.2585

**Headquarters, East Manufacturing Facility**  
44 Harbor Park Drive  
Port Washington, NY 11050

**South East Manufacturing Facility**  
1600 Distribution Ct  
Lithia Springs, GA 30122

**Central Manufacturing Facility**  
1700 South J Elmer Freeway, Ste 100  
Cedar Hill, TX 75104

**West Manufacturing Facility**  
1750 S Archibald Ave  
Ontario, CA 91761

# Atmosphere Pro 2.5"

## Invisible Trim Housing



### INVISIBLE TRIM INSTALLATION

Trim Model	Trim Description	Ceiling Thickness		
		1/2"	1"	1 1/2"
<b>A1RA-D</b>	<i>Downlight</i>	Yes	Yes	Yes
<b>A1RA-S</b>	<i>Shallow Regressed Trim</i>	Yes	Yes	Yes
<b>A1RA-A</b> <b>A1RA-P</b>	<i>Adjustable/ Pinhole</i>	Yes, to 45°	Yes, to 35°	Yes, to 20°
<b>A1RA-W</b>	<i>Wall Wash</i>	Yes	Yes	No

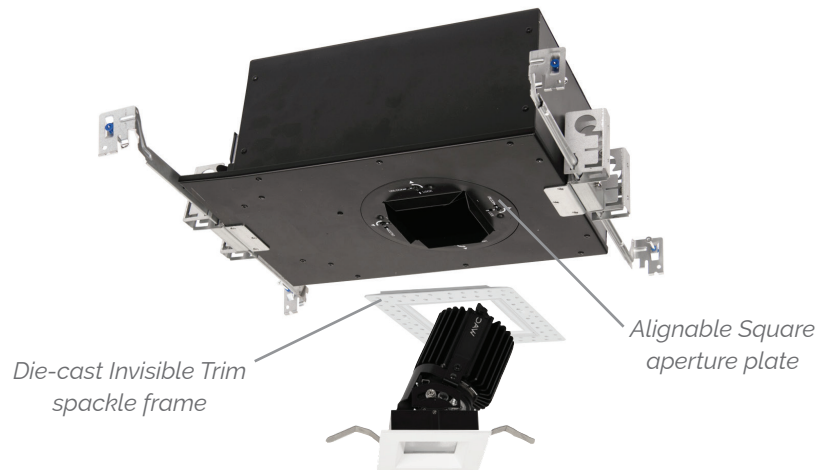
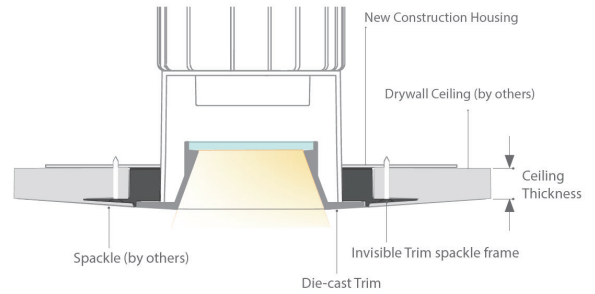



**Natural White CCT Tuning:**

The CCT of an Atmosphere fixture may be adjusted.

Using the DMX byte values in the adjacent table mapped to CH1 and CH2 of the desired output, the Atmosphere fixture may be tuned in increments of 100K (Kelvin) from 2700K to 6500K for C1 and 1800K to 4000K for C2, at full intensity.

**Note:** Through compatible RDM tool, fixture channels can be reassigned to desired consecutive channels. Factory default is DMX channel 1 and 2.

**ATMOSPHERE Pro 2.5" DMX Value vs CCT**

**C1 DMX**  
Byte Values at Full Intensity

CCT (K)	CH 1: Intensity	CH 2: CCT
6500	255	252
6400	255	249
6300	255	245
6200	255	241
6100	255	238
6000	255	232
5900	255	229
5800	255	228
5700	255	222
5600	255	217
5500	255	212
5400	255	208
5300	255	204
5200	255	199
5100	255	194
5000	255	190
4900	255	185
4800	255	179
4700	255	173
4600	255	168
4500	255	160
4400	255	152
4300	255	144
4200	255	138
4100	255	131
4000	255	123
3900	255	115
3800	255	107
3700	255	98
3600	255	89
3500	255	80
3400	255	71
3300	255	62
3200	255	51
3100	255	41
3000	255	30
2900	255	16
2800	255	4
2700	255	0

**C2 DMX**  
Byte Values at Full Intensity

CCT (K)	CH 1: Intensity	CH 2: CCT
4000	255	255
3900	255	253
3800	255	247
3700	255	241
3600	255	233
3500	255	225
3400	255	219
3300	255	210
3200	255	202
3100	255	193
3000	255	185
2900	255	176
2800	255	166
2700	255	154
2600	255	141
2500	255	126
2400	255	109
2300	255	82
2200	255	79
2100	255	64
2000	255	46
1900	255	26
1800	255	0



## Spectral Matching to Natural Light

- ATMOSPHERE technology delivers optimized spectral syncing to natural light in a tunable white solution
- ATMOSPHERE maximizes the emotional elements of light and color to deliver a first class human experience
- ATMOSPHERE significantly reduces the blue spike and cyan valley to deliver a closer match to natural light

### What is Human Centric Lighting (HCL)

- Throughout evolution, the human visual system has evolved under the natural light of sun and fire.
- Human-centric lighting by definition encompasses the effects of lighting on the physical and emotional -being of people.
- As part of the HCL initiative, there is a drive to develop "natural" sources of lighting. The human species has been conditioned to function in daylight hours by the light of the sun, and after dusk, of the warm glow of fire. Thus, we define natural light sources as those which match the spectral distribution of sunlight and firelight.

### Human Centric Light Spectrum

FEATURES	BENEFITS
Spectrum engineered to closely emulate natural light with reduced short blue wavelength intensity	Full, consistent light spectrum with fewer spectral spikes, the closest match to natural light available
Natural and vivid color rendering	Typical 98 CRI. Excellent TM-30 metrics; Skin tones and artwork render impeccably
High efficacy human-centric spectra	Greater energy savings, lower utility and environment costs
Affordable spectra optimized for humans	Accelerate adoption of full spectrum natural lighting