

# INSTALLATION INSTRUCTION

## MICRO ALPINE - TRIMMED ADJUSTABLE

A2RU-2A46, A2RU-2A56



**WARNING:**

IMPORTANT: NEVER attempt to do any work without shutting off the electricity.

- Read all instructions before installing.
- System is intended for installation by a qualified electrician in accordance with the National Electrical Code and local regulations.
- Go to the main fuse box, or circuit breaker. Place the main power switch in the "OFF" position and unscrew the fuse(s) or switch "OFF" the circuit breaker switch(es) that control the power to the fixture or room that you are working on.
- Place the wall switch in the "OFF" position.

**AVERTISSEMENT:**

IMPORTANT: Coupez l'électricité avant TOUTE manipulation.

- Lisez toutes les instructions avant d'installer.
- Système est destiné à être installé par un électricien qualifié en conformité avec le code national de l'électricité et les règlements locaux.
- Accédez au panneau central de disjoncteurs ou de fusibles de votre demeure et placez l'interrupteur principal en position d'arrêt (« OFF »).
- Placez l'interrupteur mural en position d'arrêt (« OFF »).

**CAUTION:**

All parts must be used as indicated in these instructions. Do not substitute any parts, leave parts out, or use any parts that are worn out or broken. Failure to follow this instruction could invalidate the ETL/cETL listing of this fixture.

**OVERVIEW:**

Housing is IC rated, suitable for grid, millwork or drywall ceiling installation. Housing requires a remote power supply to power the LED and a trim for a finished look. Refer to specification sheets for compatible remote power supply and trim options.

**OVERALL HOUSING DIMENSION**

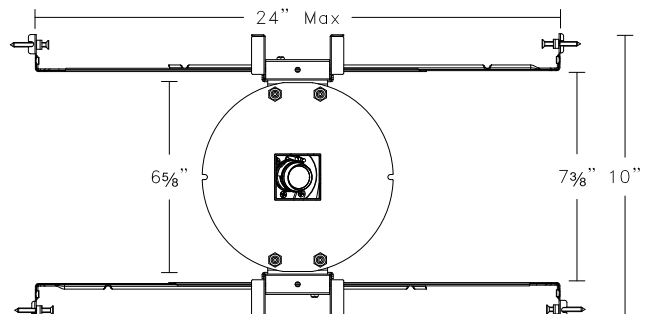
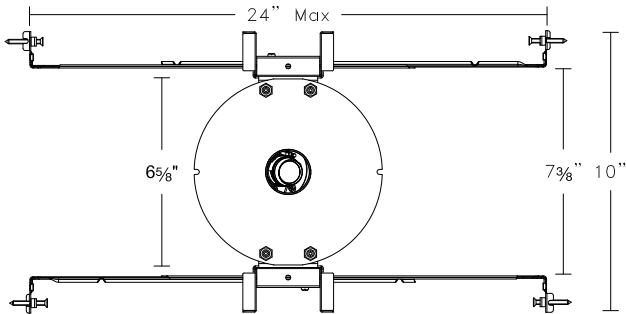
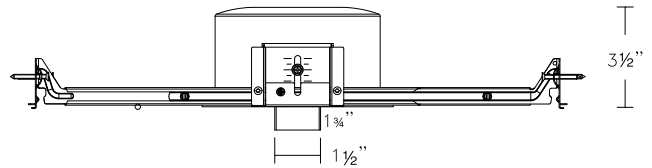
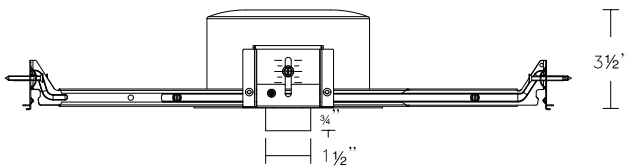

A2RU-2A46

A2RU-2A56

SPECIFICATIONS	
Housing Input	DC 18V, 600mA Constant Current
Ceiling Cutout	Round: 1 5/8" diameter Square: 1 5/8" x 1 5/8"

Installation Type	Ceiling Thickness	Minimum Required Ceiling Plenum Height
Grid	1/2" - 3/4"	4 1/2"
Millwork	1/2"	4 1/2"
	3/4"	4 1/4"
	1" - 2"	4"
Drywall	1/2" or 5/8"	4 1/2"

# INSTALLATION INSTRUCTION

## MICRO ALPINE - TRIMMED ADJUSTABLE

### A2RU-2A46, A2RU-2A56

#### INSTALLATION ON GRID CEILING

1. Cut out a 15/8" diameter round or 15/8" x 15/8" square hole based on housing style on the ceiling panel. (See **FIG. 1**). Install ceiling panel on grid.

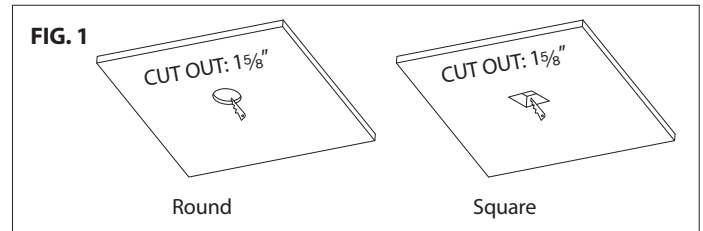

2. Housing features mounting brackets that can be used with hanger bars or various channel supports (See **FIG. 2 – FIG. 4**).

Slide the male and female hanger bars or other channel supports through the appropriate holes in the mounting brackets.

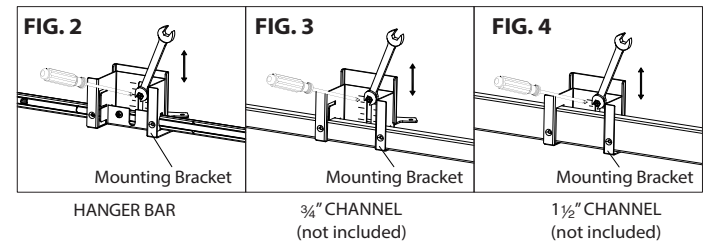

3. Hanger bars are notched on the ends to fit over "T" bars in the suspended ceilings supported with tie wires (by others) to upper ceiling structure (See **FIG. 5A**). Channels are placed on top of "T" bars and can be secured with tie wires (See **FIG. 5B**). Slide the housing along the hanger bars or channels to the desired position. Tighten bar locking screws to secure the housing in place (See **FIG. 6**). If channels are used, remove the locking screws from their original locations and reattach them to the channel locking holes to secure the housing in place.

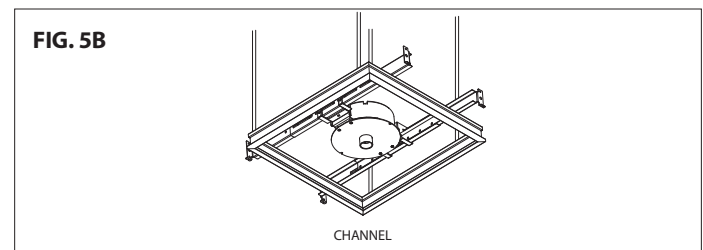
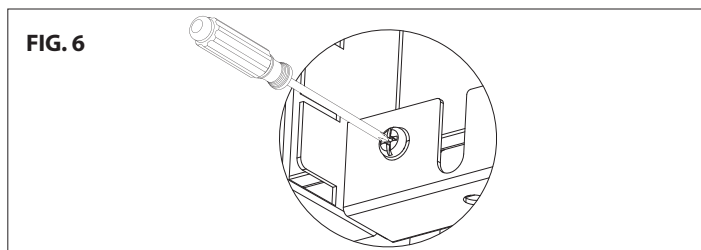
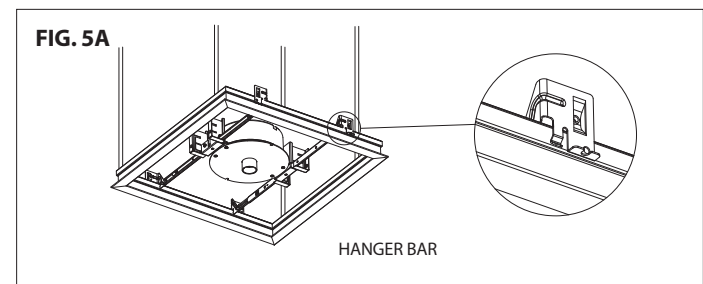

4. Using a Phillips head screwdriver or a wrench, adjust the mounting brackets to proper height by loosening two hex head screws such that the bottom of the housing collar is flush to the bottom of the ceiling. Use the position of the hex head screw, in relation to the horizontal lines on the bracket, as a reference to adjust the mounting brackets on other fixtures (See **FIG. 2 – FIG. 4**).

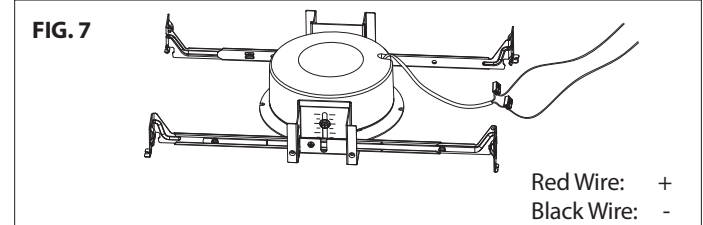

5. Connect two wire leads from the remote power supply using two WAGO connectors pre-installed on housing wire leads (See **FIG. 7**). Refer to remote power supply instruction for fixture and dimmer wiring.

6. Remove the bottom cap of the Service Tool (A2RU-TOOL) to expose the flat head screwdriver. Locate the adjustment slot inside the housing collar opening and insert the tip of the screwdriver inside the slot (see **FIG. 8**).

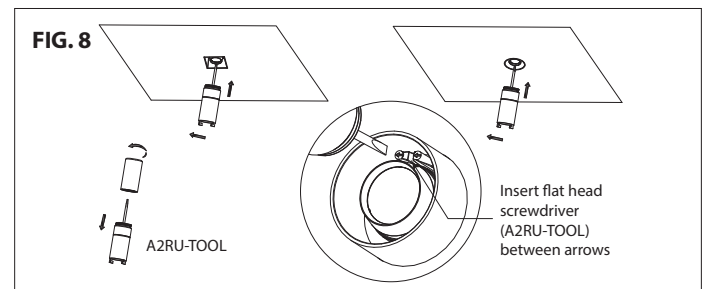

# INSTALLATION INSTRUCTION

## MICRO ALPINE - TRIMMED ADJUSTABLE

### A2RU-2A46, A2RU-2A56

For horizontal rotation, gently twist the screwdriver inside the adjustment slot to rotate the optical assembly until the two arrows on the adjustable slot surface point in the desired direction (See **FIG. 9**).

For vertical tilt, gently push the screwdriver inside the adjustment slot in the direction indicated by the two arrows until the desired tilt angle is reached (See **FIG. 8** and **FIG. 10**).

Refer to "**REFLECTOR INSTALLATION**" Section to change from pre-installed "F" (flood beam) reflector to a different reflector included with the trim package.

7. Install the trim and reflector assembly by gently pushing it inside the housing collar opening. Ensure the flange of the trim is pressed against the ceiling surface (See **FIG. 11**).

#### INSTALLATION ON JOIST WITH DRYWALL CEILING

1. Install the hanger bar and housing assembly such that the lip of the hanger bar rests on the bottom surface of the joist. Use a screwdriver or hammer to secure the "screw-nail" into the wood (See **FIG. 12 – FIG. 14**).
2. Slide the housing along the hanger bars to the desired position. Tighten bar locking screws to secure the housing in place (See **FIG. 6**).
3. Using a Phillips head screwdriver or a wrench, adjust the mounting brackets to proper height by loosening two hex head screws such that the bottom of the housing collar is flush to the bottom of the ceiling. Use the position of the hex head screw, in relation to the horizontal lines on the bracket, as a reference to adjust the mounting brackets on other fixtures (See **FIG. 2**).
4. Connect two wire leads from the remote power supply using two WAGO connectors pre-installed on housing wire leads (See **FIG. 7**). Refer to remote power supply instruction for fixture and dimmer wiring.
5. Cut out a 1 5/8" diameter round or 1 5/8" x 1 5/8" square hole based on housing style on the ceiling panel. (See **FIG. 1**). Install the drywall ceiling.

Refer to Steps 6 and 7 in "**INSTALLATION ON GRID CEILING**" Section to complete installation.

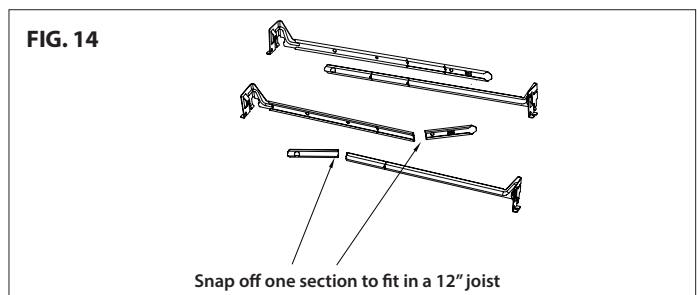
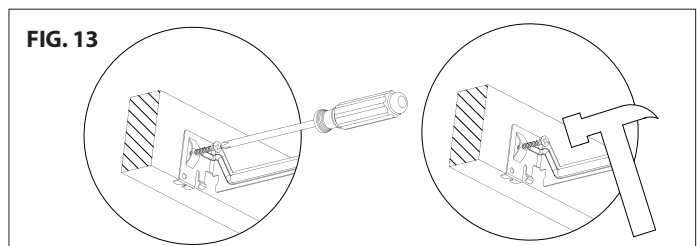
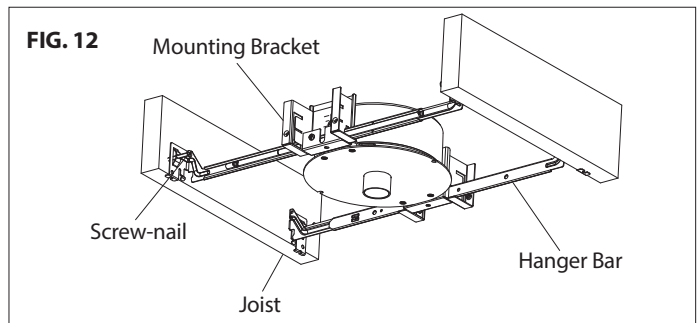
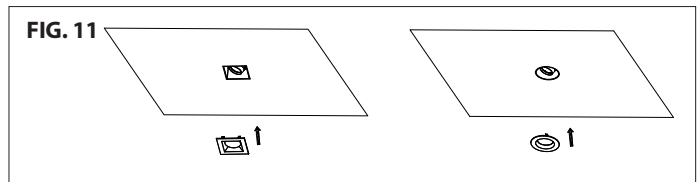
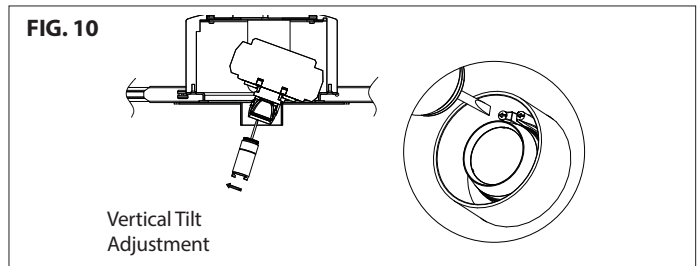
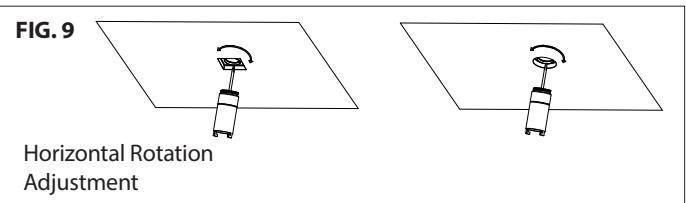

# INSTALLATION INSTRUCTION

## MICRO ALPINE - TRIMMED ADJUSTABLE

### A2RU-2A46, A2RU-2A56

#### INSTALLATION ON MILLWORK CEILING

##### Installation on **w"** or Less Thickness Panel

1. Cut out a 1 5/8" diameter round or 1 1/4" x 1 5/8" square hole based on housing style on the ceiling panel. (See **FIG. 1** and **FIG. 15**).
2. Place the housing on top of the millwork panel and fit the housing collar inside the cutout hole (See **FIG. 16**).
3. Using a Phillips head screwdriver, adjust the mounting brackets to proper height by loosening two hex head screws such that the bottom of the housing collar is flush to the bottom of the ceiling. Use the position of the hex head screw, in relation to the horizontal lines on the bracket, as a reference to adjust the mounting brackets on other fixtures (See **FIG. 17**).
4. Use two #6 wood screws with proper length (not included with the housing) to fasten on holes located at the bottom of the mounting bracket to secure the housing to the millwork panel (See **FIG. 18**).  
**Note:** Hanger bars can also be used for additional support. Contractor to confirm housing is secure to meet job requirements.
5. Connect two wire leads from the remote power supply using two WAGO connectors pre-installed on housing wire leads (See **FIG. 7**). Refer to remote power supply instruction for fixture and dimmer wiring. Refer to remote power supply instruction for fixture and dimmer wiring.

Refer to Steps 6 and 7 in "**INSTALLATION ON GRID CEILING**" Section to complete installation.

**FIG. 15**

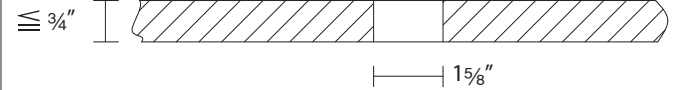

**FIG. 16**

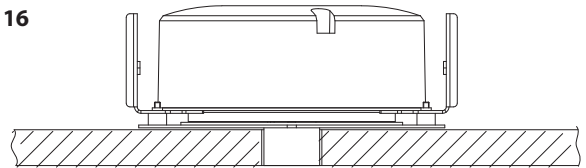

**FIG. 17**

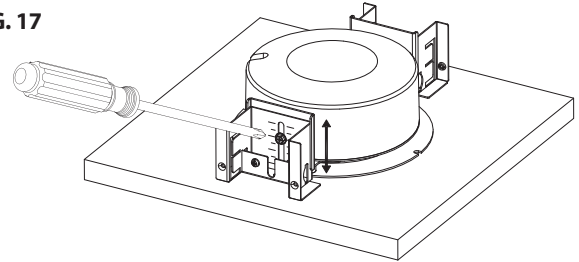

**FIG. 18**

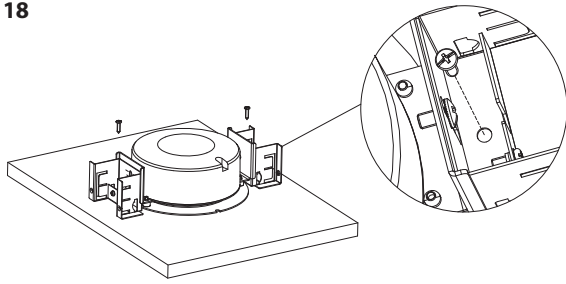

# INSTALLATION INSTRUCTION

## MICRO ALPINE - TRIMMED ADJUSTABLE

### A2RU-2A46, A2RU-2A56

#### Installation on Larger Than ¾" Thickness Panel

1. Route a 7 ¾" diameter round pocket on top of the panel to reduce the thickness to ¾" (See **FIG. 19**). Cut out a 1 5/8" diameter round or 1 5/8" x 1 5/8" square hole based on housing style on the center of the routed circle (**FIG. 19**).
2. Use a Phillips screwdriver to remove the mounting brackets from the housing and have them properly disposed (See **FIG. 20**). Place the housing inside the routed pocket on top of the millwork panel and fit the housing collar inside the cutout hole on the center (See **FIG. 21**).
3. Use two #6 wood screws with proper length (not included with the housing) to fasten on two notches located at the bottom plate to secure the housing to the millwork panel (See **FIG. 22**).
4. Connect two wire leads from the remote power supply using two WAGO connectors pre-installed on housing wire leads (See **FIG. 7**). Refer to remote power supply instruction for fixture and dimmer wiring.

Refer to Steps 6 and 7 in "**INSTALLATION ON GRID CEILING**" Section to complete installation.

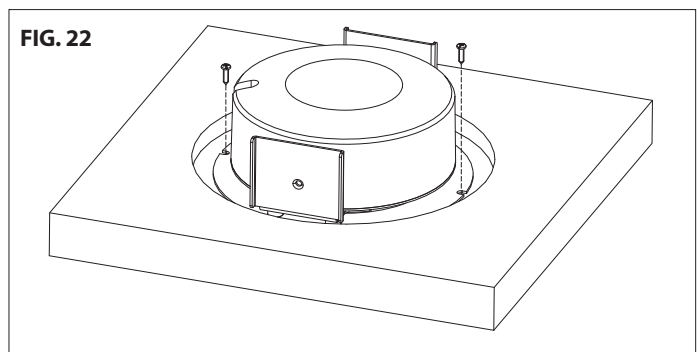
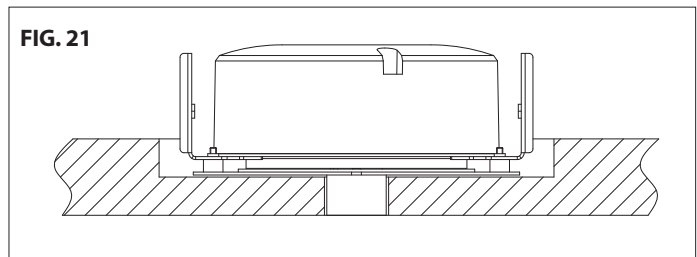
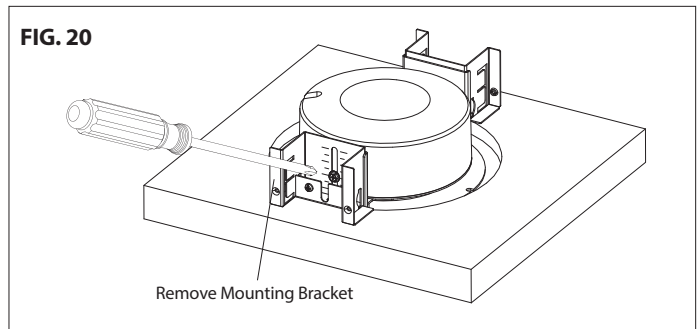
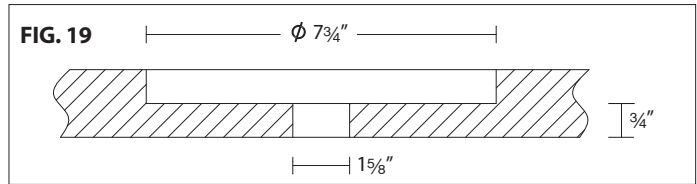

# INSTALLATION INSTRUCTION

## MICRO ALPINE - TRIMMED ADJUSTABLE

### A2RU-2A46, A2RU-2A56

#### REFLECTOR INSTALLATION

1. Tilt the light engine assembly to vertical position using the service tool (A2RU-TOOL) (See **FIG. 8** and **FIG.10**).
2. Screw on the bottom cap on the service tool and remove the top cylinder to expose the hook. Insert the tip of the hook inside the internal slit of the reflector holder and gently pull down the optical assembly. Disconnect the wire connector (See **FIG. 23**).
3. Use a fingernail or the flat head screwdriver of the service tool to disengage one tab of the reflector holder from the light engine. Gently separate the reflector holder from the light engine by disengaging the other tab on the opposite side (See **FIG. 24**).
4. Remove the pre-installed "F" (flood beam) reflector from the reflector holder and install the desired reflector included with the trim package.
5. Connect the optical assembly to the wire connector, using a finger to push the wire leads back into the cavity on the side of the optical assembly receptacle. Ensure that the wire leads do not tangle and block the optical assembly receptacle. Push the optical assembly through the housing collar by hand, ensuring its base fully engages with the magnet of the receptacle (See **FIG. 27**).
6. Restore the desired tilt angle using the flathead screwdriver of the service tool (See **FIG. 10**).

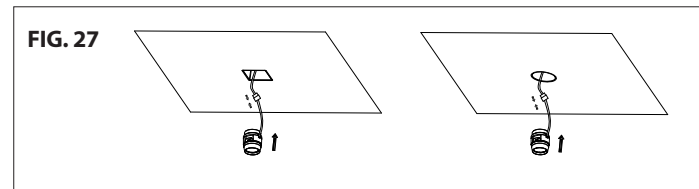
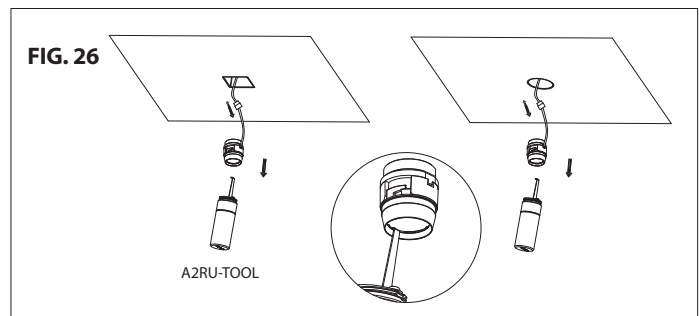
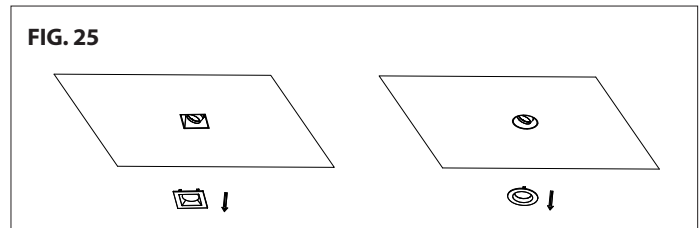
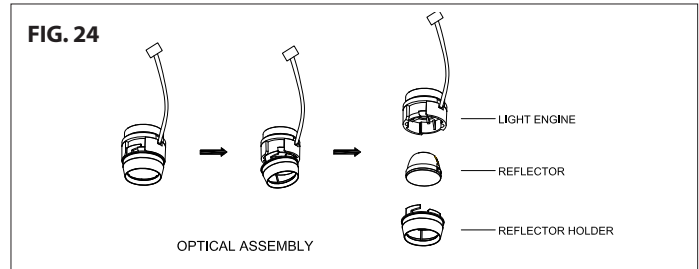
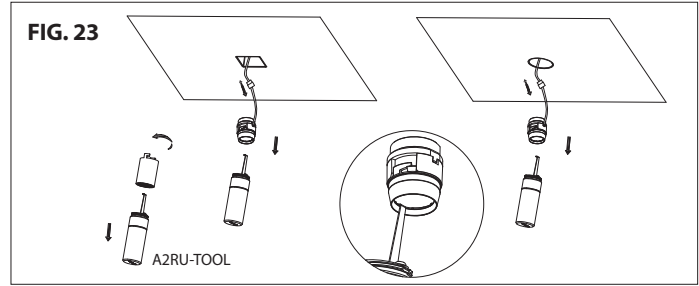

#### SERVICING TRIM AND LIGHT ENGINE

(With Service Tool A2RU-TOOL)

##### Removing Trim

**Note:** Turn off power and let trim cool down before removal.

To remove trim, simply use fingers to grip the edge of trim and gently pull it down to remove it from the housing. (See **Fig. 25**)

##### Replacing Light Engine

1. Insert the tip of the hook inside the internal slit of the reflector holder and gently pull down the optical assembly. Disconnect the wire connector (See **FIG. 26**).
2. Use a fingernail or the flat head screwdriver of the service tool to disengage one tab of the reflector holder from the light engine. Gently separate the reflector holder from the light engine by disengaging the other tab on the opposite side (See **FIG. 24**). Replace the light engine and reinstall the reflector and its holder to the light engine.
3. Connect the optical assembly to the wire connector, use a finger to push wire leads back to the cavity of housing on side of the optical assembly receptacle. Ensure that the wire leads do not tangle and block the optical assembly receptacle. Push the optical assembly through the housing collar by hand, ensuring its base fully engages with the magnet of the receptacle (See **FIG. 27**).

#### REMOTE POWER SUPPLY WIRING

Refer to relative instructions of remote power supply for installation of power supply.